

TABLE OF CONTENTS

SF-18 cover sheet

- A. Price
- B. Scope of Work
- C. Packaging and Marking
- D. Inspection and Acceptance
- E. Deliveries/Performance
- F. Administrative Data
- G. Special Requirements
- H. Clauses
- I. List of Attachments
- J. Quotation Information
- K. Evaluation Criteria
- L. Representations, Certifications and Other Statements of Offerors or Quoters

Attachments:

Attachment 1: Drawings

REQUEST FOR QUOTATIONS

A. PRICE

A.1 VALUE ADDED TAX (VAT). The Government will not reimburse the Contractor for VAT under this contract. The Contractor shall not include a line for VAT on Invoices as the U.S. Embassy has a tax exemption certificate with the host government. VAT Exemption document will be processed through Ministry of Foreign Affairs for the order which has the total price excludes VAT at or more than 5,000 THB for local VAT registered contractor under Section 82/3 of Thai Revenue Code only. The contractor will receive the document within 150 days after submitting the invoice.

A.2 The Contractor shall complete all work, including furnishing all labor, material, equipment and services required under this purchase order for the following firm fixed price and within the time specified herein. This price shall include all labor, materials, overhead and profit.

<u>Line Item</u>	<u>Description</u>	<u>QTY</u>	<u>Price</u>	<u>Total</u>
001	CAT6A Plenum Cable and Equipment + UTP CAT6A Solid CMP Plenum Blue (TEL) (LMZ-LUU6A-PBU) + Cable Management (LMZ-HCM1U) + RJ-45 CAT6A Blue (TEL) (LMZ-MJAKC6ABU) + Cable Management (LMZ-HCM1U) + Face (LMZ-FP1S) + CAT6A Patch Panel 24 Port Blue (TEL) (LMZ-MPPD24) + CAT6A Patch Cord 3M Blue (TEL) (LMZ-PCL6ABL03) + CAT6A Patch Cord 2M Blue (TEL) (LMZ-PCL6ABL02) + Fiber Optic MM OM4 12 Core (LMZOM4IDTB12C-LZ) + Pigtail LC MM OM4 (LMZ-LCUCOM4-AQM02-PK) + Rack Mouse Drawer (LMZ-FPR14S) + Snap Place LC MM 12 Core (LMZ-F1AP06DLCMM) + Splicing Tray (LMZ-SP01) + Sleeve (LMZ-SLEEVE) + Blank Adapter (LMZ-F1AP00)	1 LOT		

	+ Patch Cord MM OM4 LC-LC 3M (LMZ-LCLCOM4DAQ03) + Rack Cabinet			
002	Service +Installation +Cabling Install +Remove old cabling +Test and Report +Transportation	1 LOT		
003	DBA Insurance	1 LOT		

B. SCOPE OF WORK

The Contractor shall install CAT6A cabling throughout each dormitory rooms and common areas which total of 132 drops. All UTP CAT6A cable must be “BLUE” color. The Contractor shall also provide two (2) new communication racks of 27U which will be located on the third and fifth floor to interlink with the existing communication rack on the first floor. The rack on the third floor shall be the main distribute point between second and third floor; and the rack on the fifth floor shall be the main distribute point between fourth, fifth and sixth floor. All racks must have a patch panels with labeling according to the cabling standard following ANSI/TIA/EAI standards, 568-A, 569-A, 606 and 607 (EIA standards). All cabling shall comply with ANSI/ICEA S-80-576. These interlink between racks must be fiber optic cable with multi-mode of no less than 12 cores. The Contractor shall install the new and remove the old cabling.

The Contractor shall use and follow the following diagram as a baseline for cabling design but are not limited to as followed:

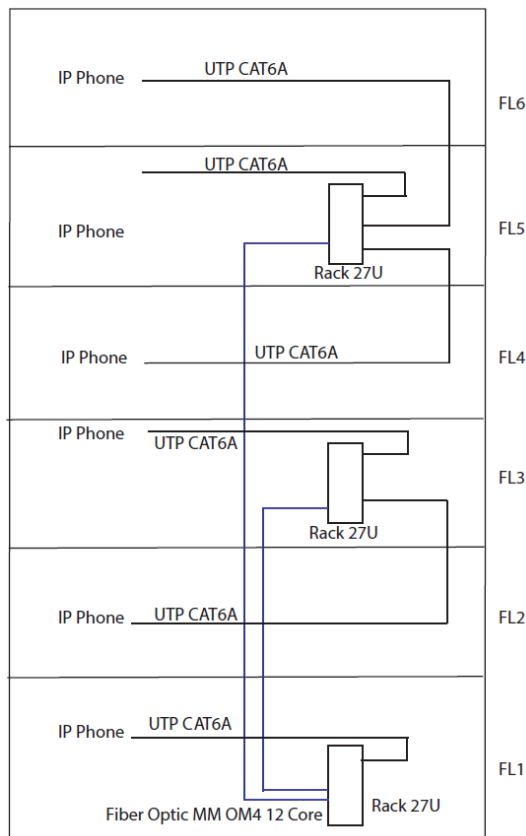

The Contractor shall provide and install new floor standing or wall mount cabinet size-appropriate communication racks with appropriate new power outlet to the rack and uninterruptible power supply (UPS) with CAT6A patch panels mounted inside for each communication closet that will have new cabling, as indicated during the site survey.

The Contractor shall provide and install ladder racks and run all cables on ladder racks; and terminate new cable runs to these patch panels and dress the cables professionally.

The Contractor shall provide and install new cable trays in hallways and office, above drops ceiling where possible, as indicated during the site survey.

The Contractor shall install new Work Area Outlets (WAO) referred to as “faceplates”. Each WAO must consist of one (1) drop and each WAO will consist of one (1) blue CAT6A CMP plenum cable connected to color matched CAT6A keystone jack installed in two (2) port boxes at the locations specified during the site survey.

The Contractor shall provide and install new surface mount raceway at all new WAO locations that do not have existing cable pathway.

The Contractor shall provide and run CAT6A solid CMP Plenum cable from communication closets to each WAO; and all visible cable must be concealed professionally to match with the existing surface.

The Contractor shall provide and install appropriate length CAT6 Plenum CMP patch cables between patch panels and current networking equipment.

The Contractor shall provide and install appropriate length CAT6A Plenum CMP patch cables between drops and current end devices (workstations, photocopier, printer, scanner, access control, and telephone).

All cable terminations will maintain the twists of the pairs as close as possible to the point of termination, no more than two (2) cm untwisted.

The Contractor shall provide and install all necessary equipment for single mode fiber optic cable interlink between existing communication rack and communication closets, as indicated during the site survey.

No plastic cable “zip” ties will be used for cable management. Cables dressing must be grouped together using Velcro straps or equivalent product, easily removable equipment.

Drawings: In case of differences between small and large scale drawings, the later will govern. Where a portion of the work is drawn in detail and the remainder of the work is indicated in outline, the parts drawn in detail shall apply also to all other portions of the work.

Administration: Contractor shall provide a submittal for COR approval, within ten (10) days after contract award, drawings showing the proposed cable routing, conduits, pathways from the station equipment to the telecommunications closets, telephone distribution frame and vertical cable sizes. Upon completion of the installation work, Contractor shall submit final wiring diagram drawings to the COR. See EIA standard 606 for details.

Security: An awarded contractor must submit a name list of workers including their ID number and vehicle license plate to COR one week prior starting the job.

Testing: The Contractor shall perform pre-qualification testing during installation to ensure quality control and that the cabling system will pass qualification testing.

The Contractor shall test and label all new drop locations and patch panels.

The Contractor must test all drops to CAT6A standards with CAT6A certified testing equipment. A full report listing all test results and performance of all drops must be provided to COR.

The Contractor must perform and document continuity and wire map testing on each cable installed between drops and patch panels to ensure that the cable pairs are properly connectorized.

The Contractor must perform and document link attenuation tests on each cable installed between drops and patch panels. Maximum attenuation levels are:

Frequency (MHz) CAT-6	Link Test (dB) CAT-6
1	3
4	3.5
8	5
10	5.6
16	7
20	7.9
25	8.9
31.25	10
62.5	14.4
100	18.6
200	27.4
250	31.1

The Contractor must test and document NEXT (crosstalk) on each cable installed between drops and patch panels using a Level III certified field tester.

The Contractor must test and document DELAY and DELAY SKEW on each cable installed between drops and patch panels using a Level III certified field tester.

Removal of Existing Wiring: Upon completion and passing of tests identified above, contractor shall remove old cabling including all existing faceplates and cables. This shall be done minimizing any property damage to walls, ceilings, carpets effected by the removal. Contractor is responsible for restoring walls, ceiling, and carpeting to their original condition. If cutting is necessary it shall not impair structural stability of the building and system and contractor shall patch and paint (if on wall or ceiling) affected areas.

Patching & Repair: Patching Material shall match existing materials in type and quality and be specifically designed to fill holes, spaces, and voids and cavities at communication penetrations and where old cabling removed. Patching material shall be made of firestopping materials. Restore patched surfaces as close to the original condition and finish as possible. Where patching occurs smooth surface to be painted and extend, paint coat over entire unbroken surface containing the patched area. Patched areas shall be primed first and finished with two coats of paint so that patch blends into existing surface. The Contractor shall provide all necessary concealer work including re-paint work wherever possible or caused from work.

C. PACKAGING AND MARKING

Materials delivered to the site shall be marked as follows:

US EMBASSY BANGKOK (ILEA Phone Cabling Project)

D. INSPECTION AND ACCEPTANCE

The COR, or his/her authorized representatives, will inspect from time to time the services being performed under this contract and the supplies furnished to determine whether work is being performed in a satisfactory manner, and that all supplies are of acceptable quality and standards.

The Contractor shall be responsible for any countermeasures or corrective action, within the scope of this contract, which may be required by the Contracting Officer as a result of such inspection.

Substantial Completion

Definitions:

(a) "*Substantial Completion*" means the stage in the progress of the work as determined and certified by the Contracting Officer in writing to the Contractor, on which the work (or a portion designated by the Government) is sufficiently complete and satisfactory. Substantial completion means that the property may be occupied or used for the purpose for which it is intended, and only minor items such as touch-up, adjustments, and minor replacements or installations remain to be completed or corrected which:

- (1) do not interfere with the intended occupancy or utilization of the work, and
- (2) can be completed or corrected within the time period required for final completion.

(b) The "*date of substantial completion*" means the date determined by the Contracting Officer or authorized Government representative as of which substantial completion of the work has been achieved.

Use and Possession upon Substantial Completion - The Government shall have the right to take possession of and use the work upon substantial completion. Upon notice by the Contractor that the work is substantially complete (a Request for Substantial Completion) and an inspection by the Contracting Officer or an authorized Government representative (including any required tests) the Contracting Officer shall furnish the Contractor a Certificate of Substantial Completion, accompanied by the Schedule of Defects listing items of work remaining to be performed, completed or corrected before final completion and acceptance. Failure of the Contracting Officer to list any item of work shall not relieve the Contractor of responsibility for complying with the terms of the contract. The Government's possession or use upon substantial completion shall not be deemed an acceptance of any work under the contract.

Final Completion and Acceptance

Definitions:

(a) "*Final completion and acceptance*" means the stage in the progress of the work as determined by the Contracting Officer and confirmed in writing to the Contractor, on which all

work required under the contract has been completed in a satisfactory manner, subject to the discovery of defects after final completion, and except for items specifically excluded in the notice of final acceptance.

(b) The "*date of final completion and acceptance*" means the date determined by the Contracting Officer when final completion of the work has been achieved, as indicated by written notice to the Contractor.

Final Inspection and Tests

The Contractor shall give the Contracting Officer at least five (5) days advance written notice of the date the work will be fully completed and ready for final inspection and tests. Final inspection and tests will be started not later than the date specified in the notice unless the Contracting Officer determines that the work is not ready for final inspection and so informs the Contractor.

Final Acceptance

If the Contracting Officer is satisfied that the work under the contract is complete (with the exception of continuing obligations), the Contracting Officer shall issue to the Contractor a notice of final acceptance and make final payment upon:

- satisfactory completion of all required tests,
- a final inspection that all items by the Contracting Officer listed in the Schedule of Defects have been completed or corrected and that the work is finally complete (subject to the discovery of defects after final completion), and
- submittal by the Contractor of all documents and other items required upon completion of the work, including a final request for payment.

E. DELIVERIES OR PERFORMANCE

52.211-10 COMMENCEMENT, PROSECUTION, AND COMPLETION OF WORK (APR 1984)

The Contractor shall be required to (a) commence work under this contract on the date the Contractor receives the notice to proceed, (b) prosecute the work diligently, and (c) complete the entire work ready for use not later than 90 days after Notice to Proceed. The time stated for completion shall include final cleanup of the premises and completion of punch-list items

Contractor's Submission of Schedules

(a) The time for submission of the finalized schedules referenced in FAR 52.236-15, "Schedules for Construction Contracts", paragraph (a), is hereby modified to reflect the due date for submission as **seven (7)** calendar days after receipt of an executed contract".

(b) These schedules shall include the time by which shop drawings, product data, samples and other submittals required by the contract will be submitted for approval.

(c) The Contractor shall revise such schedules (1) to account for the actual progress of the work, (2) to reflect approved adjustments in the performance schedule, and (3) as required by the Contracting Officer to achieve coordination with work by the Government and any separate contractors employed by the Government. The Contractor shall submit a schedule which sequences work so as to minimize disruption at the jobsite.

(d) All deliverables shall be in the English language, unless otherwise provided hereunder, and any system of dimensions (i.e., English or metric) shown shall be consistent with that used in the contract. No extension of time shall be allowed on account of a delay by the Government in approving such deliverables if the Contractor has failed to act promptly and responsively in submitting its deliverables. Each deliverable shall be identified as required by the contract.

(e) Acceptance of Schedule: When the Government has accepted any time schedule, it shall be binding upon the Contractor. The completion date is fixed and may be extended only by a written contract modification signed by the Contracting Officer. Acceptance or approval of any schedule or revision thereof by the Government shall not (1) extend the completion date or obligate the Government to do so, (2) constitute acceptance or approval of any delay, nor (3) excuse the Contractor from or relieve the Contractor of its obligation to maintain the progress of the work and achieve final completion by the established completion date.

Notice of Delay

If the Contractor receives a notice of any change in the work, or if any other conditions arise which are likely to cause or are actually causing delays which the Contractor believes may

result in completion of the project after the completion date, the Contractor shall notify the Contracting Officer of the effect, if any, of such change or other conditions upon the approved schedule, and shall state in what respects, if any, the relevant schedule or the completion date should be revised. The Contractor shall give notice not more than ten (10) days following the first occurrence of event giving rise to the delay or prospective delay. Revisions to the approved time schedule shall only be made with the approval of the Contracting Officer.

Notice to Proceed

(a) Following receipt from the Contractor of any bonds or evidence of insurance within the time specified in Section G of this order, and following acceptance of these documents by the Contracting Officer, the Contracting Officer will provide to the Contractor a Notice to Proceed. The Contractor must then prosecute the work required hereunder, commencing and completing performance not later than the time period established in the contract.

(b) It is possible that the Contracting Officer may elect to issue the Notice to Proceed prior to receipt and acceptance of any bonds or evidence of insurance required hereunder. Issuance of a Notice to Proceed by the Government before receipt of the required bonds or insurance certificates or policies shall not be a waiver of the requirement to furnish these documents.

Working Hours

All work shall be performed during **Monday to Friday at 08.00 to 17.00 hrs.** Other hours, if requested by the Contractor, may be approved by the COR. The Contractor shall give 24 hours notification in advance to COR who will consider any deviation from the hours identified above. Changes in work hours, initiated by the Contractor, will not be a cause for a price increase. ILEA classes must not be interrupted or affected in any way by this work including excessive noise.

Pre-Construction Conference

A preconstruction conference will be held 10 days after contract award at ILEA Bangkok, 88/8 Moo 3, Vibhavadi-Rangsit Road, Talad Bangkhen, Laksi, Bangkok, Thailand, 10210 to discuss the schedule, submittals, notice to proceed, mobilization and other important issues that effect construction progress. See FAR 52.236-26, PreConstruction Conference.

Deliverables

The following items shall be delivered under this contract:

<u>Description</u>	<u>Qty</u>	<u>Delivery Date</u>	<u>Deliver To:</u>
G. Securities/Insurance Certificate	1	10 days after award	CO
E. Construction Schedule	1	7 days after award	COR
E. Pre-Construction Conference	1	10 days after award	COR

G. Bios on Personnel	1	10 days after award	COR
F. Payment Request	1	Last calendar day of each month	COR
D. Request for Substantial Completion	1	5 days before inspection	COR
D. Request for Final Acceptance	1	5 days before inspection	COR
B. Installation Submittal	1	10 days after contract award	COR

F. ADMINISTRATIVE DATA

652.242-70 CONTRACTING OFFICER'S REPRESENTATIVE (COR) (AUG 1999)

(a) The Contracting Officer may designate in writing one or more Government employees, by name or position title, to take action for the Contracting Officer under this contract. Each designee shall be identified as a Contracting Officer's Representative (COR). Such designation(s) shall specify the scope and limitations of the authority so delegated; provided, that the designee shall not change the terms or conditions of the contract, unless the COR is a warranted Contracting Officer and this authority is delegated in the designation.

(b) The COR for this contract is **ILEA Bangkok Chief of Information Technology**.

Payment: The Contractor's attention is directed to Section H, 52.232-5, "Payments Under Fixed-Price Construction Contracts". The following subsections elaborate upon the information contained therein.

Each application for payment, which shall be made no more frequently than monthly, unless otherwise provided herein, shall cover the value of labor and materials completed and in place, including a prorated portion of overhead and profit.

Following receipt of the Contractor's request for payment, and on the basis of an inspection of the work, the Contracting Officer shall make a determination as to the amount which, in his/her opinion, is then due. In the event the Contracting Officer does not approve payment of the full amount applied for, less the retainage addressed in 52.232-5, the Contracting Officer shall advise the Contractor of the reasons therefore.

Under the authority of 52.232-27(a) the 14-day period identified in FAR 52.232-27(a)(1)(i)(A) is hereby changed to 30 days.

For Prompt Payment Act purpose, the Contractor shall send the invoice to following address:

Financial Management Office
U.S. Embassy Bangkok
120 – 122 Wireless Rd.,
Lumpini, Pathumwan
Bangkok, Thailand 10330

G. SPECIAL REQUIREMENTS

G.1 Performance/Payment Protection

The Contractor shall furnish some form of payment protection as described in 52.228-13 in the amount of 50% of the contract price. This may be in the form of a bond, irrevocable letter of credit, or bank letter guarantee.

The Contractor shall provide the information required by paragraph above within ten (10) calendar days of award. Failure to timely submit the required security may result in rescinding or termination of the contract by the Government. Should the contract be terminated, the contractor will be liable for those costs as described in FAR 52.249-10, "Default (Fixed-Price Construction), which is included in this purchase order.

The bonds or alternate performance security shall guarantee the Contractor's execution and completion of the work within the contract time and the correction of any defects after completion as required by this contract, the payment of all wages and other amounts payable by the Contractor under its subcontracts or for labor and materials, and the satisfaction or removal of any liens or encumbrances placed on the work.

The required securities shall remain in effect in the full amount required until final acceptance of the project by the Government, at which time the penal sum of the performance security shall be reduced to 10% of the contract price. The security shall remain in effect for one year after the date of final completion and acceptance, and the Contractor shall pay any premium required for the entire period of coverage.

G.2 Insurance

The Contractor is required by 52.228-5, "Insurance - Work on a Government Installation" to provide whatever insurance is legally necessary. The Contractor, shall, at its own expense, provide and maintain during the entire performance period the following insurance amounts:

General Liability (includes premises/operations, collapse hazard, products, completed operations, contractual, independent contractors, broad form property damage, personal injury)

(1) Bodily injury on or off the site, stated in U.S. dollars:	
Per Occurrence	Baht 300,000.00
Cumulative	Baht 1,000,000.00
(2) Property damage on or off the site, stated in U.S. dollars:	
Per Occurrence	Baht 300,000.00
Cumulative	Baht 1,000,000.00

The foregoing types and amounts of insurance are the minimums required. The Contractor shall obtain any other types of insurance required by local law or that are ordinarily or customarily obtained in the location of the work. The limit of such insurance shall be as provided by law or sufficient to meet normal and customary claims.

The Contractor agrees that the Government shall not be responsible for personal injuries or for damages to any property of the Contractor, its officers, agents, servants, and employees, or any other person, arising from and incident to the Contractor's performance of this contract. The Contractor shall hold harmless and indemnify the Government from any and all claims arising therefrom, except in the instance of gross negligence on the part of the Government.

The Contractor shall obtain adequate insurance for damage to, or theft of, materials and equipment in insurance coverage for loose transit to the site or in storage on or off the site.

The general liability policy required of the Contractor shall name "the United States of America, acting by and through the Department of State", as an additional insured with respect to operations performed under this contract.

The Contractor shall provide evidence of the insurance required under this purchase order within ten (10) calendar days after award. Failure to timely submit this evidence, in a form acceptable to the Contracting Officer, may result in rescinding or termination of the contract by the Government.

G.3 Document Descriptions

G.3.1 Supplemental Documents

The Contracting Officer shall furnish from time to time such detailed drawings and other information as is considered necessary, in the opinion of the Contracting Officer, to interpret, clarify, supplement, or correct inconsistencies, errors or omissions in the Contract documents, or to describe minor changes in the work not involving an increase in the contract price or extension of the contract time. The Contractor shall comply with the requirements of the supplemental documents, and unless prompt objection is made by the Contractor within 20 days, their issuance shall not provide for any claim for an increase in the Contract price or an extension of contract time.

G.3.2 Record Documents

The Contractor shall maintain at the project site:

- a current marked set of drawings indicating all interpretations and clarification, contract modifications, change orders, or any other departure from the contract requirements approved by the Contracting Officer; and,
- a complete set of record shop drawings, product data, samples and other submittals as approved by the Contracting Officer.

G.3.3 "As-Built" Documents

After final completion of the work, but before final acceptance thereof, the Contractor shall provide:

- complete sets of "as-built" drawings, based upon the record set of drawings, marked to show the details of construction as actually accomplished; and,
- record shop drawings and other submittals, in the number and form as required by the specifications.

G.4 Laws and Regulations

The Contractor shall, without additional expense to the Government, be responsible for complying with all laws, codes, ordinances, and regulations applicable to the performance of the work, including those of the host country, and with the lawful orders of any governmental authority having jurisdiction. Host country authorities may not enter the construction site without the permission of the Contracting Officer. Unless otherwise directed by the Contracting Officer, the Contractor shall comply with the more stringent of the requirements of such laws, regulations and orders and of the contract. In the event of a conflict among the contract and such laws, regulations and orders, the Contractor shall promptly advise the Contracting Officer of the conflict and of the Contractor's proposed course of action for resolution by the Contracting Officer.

The Contractor shall comply with all local labor laws, regulations, customs and practices pertaining to labor, safety, and similar matters, to the extent that such compliance is not inconsistent with the requirements of this contract.

The Contractor shall give written assurance to the Contracting Officer that all subcontractors and others performing work on or for the project have obtained all requisite licenses and permits.

Proper documentation and evidence satisfactory to the Contracting Officer of compliance with this clause shall be submitted by the Contractor at such times as directed by the Contracting Officer.

G.5 Construction Personnel

The Contractor shall maintain discipline at the site and at all times take all reasonable precautions to prevent any unlawful, riotous or disorderly conduct by or amongst those employed at the site and for the preservation of peace and protection of persons and property in the neighborhood of the project against the same. The Contracting Officer may require, in writing, that the Contractor remove from the work any employee that the Contracting Officer deems incompetent, careless, insubordinate or otherwise objectionable, or whose continued employment on the project is deemed by the Contracting Officer to be contrary to the Government's interests.

If the Contractor has knowledge that any actual or potential labor dispute is delaying or threatens to delay the timely performance of this contract, the Contractor shall immediately give

notice, including all relevant information, to the Contracting Officer.

After award, the Contractor has ten (10) calendar days to submit to the Contracting Officer a list of workers and supervisors assigned to this project for the Government to conduct all necessary security checks. It is anticipated that ILEA access request / security checks will take **three (3)** days to perform. For each individual the list shall include:

Full Name
Place and Date of Birth
Current Address
Identification number

Failure to provide any of the above information may be considered grounds for rejections and/or resubmittal of the application. Once the Government has completed the security screening and approved the applicants a badge will be provided to the individual for access to the site. This badge may be revoked at any time due to the falsification of data, or misconduct on site.

The manager assigned by the Contractor to superintend the work on-site, as required by Section H, 52.236-6, "Superintendence by the Contractor," shall be fluent in written and spoken English. This individual shall also be considered key personnel under the terms of this purchase order.

G.6 Materials and Equipment

All materials and equipment incorporated into the work shall be new and for the purpose intended, unless otherwise specified, and all workmanship shall be of good quality and performed in a skillful manner as determined by the Contracting Officer.

G.6.1 Custody of Materials

The Contractor shall be responsible for the custody of all materials received for incorporation into the project, including Government furnished materials, upon delivery to the Contractor or to any person for whom it is responsible, including subcontractors. The Contractor shall deliver all such items to the site as soon as practicable. If required by the Contracting Officer, the Contractor shall clearly mark in a manner directed by the Contracting Officer all items of which the Contractor has custody but which have not been delivered or secured at the site, clearly indicating the use of such items for the U.S. Government project.

G.6.2 Basis of Contract Price

The contract price is based on the use of the materials, products and equipment specified in the contract, except for substitutions or "Or-Equal" items proposed by the Contractor which have been specifically approved by the Government at the time of execution of the contract. Any substitution approved by the Government after execution of the contract shall be subject to an appropriate adjustment of the contract price.

G.6.3 Substitutions

(a) Prior approval required. The Contractor must receive approval in writing from the Contracting Officer before substitutions (1) proposed by the Contractor but not yet approved at the time of execution of the contract, or (2) proposed by the Contractor after execution of the contract may be used in the project. Sufficient information to permit evaluation by the Government must be accompany any substitution request including but not limited to the reasons for the proposed substitution and data concerning the design, appearance, performance, composition, and relative cost of the proposed substitute. The Contractor shall make requests for substitutions in a timely manner to permit adequate evaluation by the Government. If, in the Contracting Officer's opinion, the use of such substitute items is not in the best interests of the Government, the Contractor must obtain the items originally specified with no adjustment in the contract price or completion date.

(b) Approval through shop drawings. The Contractor may propose substitutions of materials in the submittal of shop drawings, provided such substitution is specifically requested in writing in the transmittal of the shop drawings to the Contracting Officer. Such substitution requests must be made in a timely manner and supported by the required information.

(c) Final approval on delivery. Acceptance or approval of proposed substitutions under the contract are conditioned upon approval of items delivered at the site or approval by sample. Approval by sample shall not limit the Government's right to reject material after delivery to the site if the material does not conform to the approved sample in all material respects.

G.6.4 "Or-Equal Clause"

References in the Specifications/Statement of Work to materials, products or equipment by trade name, make, or catalog number, or to specific processes, shall be regarded as establishing a standard of quality and shall not be construed as limiting competition. The Contractor may propose for approval or rejection by the Contracting Officer the substitution of any material, product, equipment or process that the Contractor believes to be equal to or better than that named in the Specifications/Statement of Work, unless otherwise specifically provided in this contract.

G.7 Special Warranties

Any special warranties that may be required under the contract shall be subject to the stipulations set forth in 52.246-21, "Warranty of Construction", insofar as they do not conflict with the provisions of such special warranties.

The Contractor shall obtain and furnish to the Government all information which is required in order to make any subcontractor's, manufacturer's, or supplier's guarantee or warranty legally binding and effective, and shall submit both the information and the guarantee or warranty to the Government in sufficient time to permit the Government to meet any time limit requirements specified in the guarantee or warranty, but not later than completion and acceptance of all work under this contract.

The Contractor shall provide one (1) year products and cablings system warranty and provide one (1) year onsite service. The Contractor must be able to respond to a service request by the next day, during normal business hours (Monday through Friday, 8 am to 5 pm).

G.8 Equitable Adjustments

Any circumstance for which the contract provides an equitable adjustment, that causes a change within the meaning of paragraph (a) of the "Changes" clause shall be treated as a change under that clause; provided, that the Contractor gives the Contracting Officer prompt written notice within a limit of 20 days stating (a) the date, circumstances, and applicable contract clause authorizing an equitable adjustment and (b) that the Contractor regards the event as a changed condition for which an equitable adjustment is allowed under the contract.

The Contractor shall provide written notice of a differing site condition within 10 calendar days of occurrence in accordance with additional information provided in FAR 52.236-4, Differing Site Condition.

DOSAR 652.235-70 ACCIDENT PREVENTION (AUG 1999)

(a) General. The Contractor shall provide and maintain work environments and procedures which will (1) safeguard the public and Government personnel, property, materials, supplies, and equipment exposed to Contractor operations and activities; (2) avoid interruptions of Government operations and delays in project completion dates; and (3) control costs in the performance of this contract. For these purposes, the Contractor shall—

- (1) Provide appropriate safety barricades, signs and signal lights;
- (2) Comply with the standards issued by any local government authority having jurisdiction over occupational health and safety issues; and
- (3) Ensure that any additional measures the Contracting Officer determines to be reasonably necessary for this purpose are taken.
- (4) Designate a safety manager for this contract. The safety manager shall be responsible for coordination of safety procedures, and monitoring of those aspects of the work that pose the greatest safety risks.
- (5) If, during the performance of this contract, the Contractor encounters hazardous materials (including asbestos-containing materials, etc), the contractor shall immediately report the situation to the COR.

(b) Records. The Contractor shall maintain an accurate record of exposure data on all accidents incident to work performed under this contract resulting in death, traumatic injury, occupational disease, or damage to or theft or loss of property, materials, supplies, or equipment. The Contractor shall report this data in the manner prescribed by the Contracting Officer.

(c) Subcontracts. The Contractor shall be responsible for its subcontractors' compliance with this clause.

(d) Written Program. Before commencing the work, the Contractor shall—

- (1) Submit a written proposal for implementing this clause; and
- (2) Meet with the Contracting Officer to discuss and develop a mutual understanding relative to administration of the overall safety program.

(e) Notification. The Contracting Officer shall notify the Contractor of any non-compliance with these requirements and the corrective actions required. This notice, when delivered to the Contractor or the Contractor's representative at site, shall be deemed sufficient notice of the non-compliance and corrective action required. After receiving the notice, the Contractor shall immediately take correction action. If the Contractor fails or refuses to promptly take corrective action, the Contracting Officer may issue an order suspending all or part of the work until satisfactory corrective action has been taken. The Contractor shall not be entitled to any equitable adjustment of the contract price or extension of the performance schedule on any suspension of work issued under this clause.

G.9 Public Notification

The Contractor agrees not to use the work under this purchase order to promote or advertise its' business, without the written approval of the Contracting Officer.

H. CLAUSES

52.252-2 CLAUSES INCORPORATED BY REFERENCE (FEB 1998)

This contract incorporates one or more clauses by reference, with the same force and effect as if they were given in full text. Upon request, the Contracting Officer will make their full text available. In addition, the full text of a clause may be accessed electronically at:

Acquisition.gov this address is subject to change.

If the Federal Acquisition Regulation (FAR) is not available at the location indicated above, use the Department of State Acquisition website at e-CFR to see the links to the FAR. You may also use an Internet “search engine” (for example, Google, Yahoo or Excite) to obtain the latest location of the most current FAR.

The following Federal Acquisition Regulation clause(s) is/are incorporated by reference (48 CFR CH. 1):

<u>CLAUSE</u>	<u>TITLE AND DATE</u>
52.202-1	DEFINITIONS (JUN 2020)
52.204-7	SYSTEM FOR AWARD MANAGEMENT (OCT 2016)
52.204-9	PERSONAL IDENTIFICATION VERIFICATION OF CONTRACTOR PERSONNEL (JAN 2011)
52.204-10	REPORTING EXECUTIVE COMPENSATION AND FIRST-TIER SUBCONTRACT AWARDS (OCT 2018)
52.204-18	COMMERCIAL AND GOVERNMENT ENTITY CODE MAINTENANCE (JUL 2016)
52.204-19	INCORPORATION BY REFERENCE OF REPRESENTATIONS AND CERTIFICATIONS (DEC 2014)
52.209-6	PROTECTING THE GOVERNMENT'S INTEREST WHEN SUBCONTRACTING WITH CONTRACTORS DEBARRED, SUSPENDED, OR PROPOSED FOR DEBARMENT (JUN 2020)
52.213-4	TERMS AND CONDITIONS-SIMPLIFIED ACQUISITIONS (OTHER THAN COMMERCIAL ITEMS) (OCT 2020)
52.222-1	NOTICE TO THE GOVERNMENT OF LABOR DISPUTES (FEB 1997)
52.222-19	CHILD LABOR – COOPERATION WITH AUTHORITIES AND REMEDIES (JAN 2018)

- 52.223-18 ENCOURAGING CONTRACTOR POLICIES TO BAN TEXT MESSAGING WHILE DRIVING (JUN 2020)
- 52.225-5 TRADE AGREEMENTS (FEB 2016)
- 52.222-50 COMBATING TRAFFICKING IN PERSONS (OCT 2020)
- 52.223-18 ENCOURAGING CONTRACTOR POLICIES TO BAN TEXT MESSAGING WHILE DRIVING (AUG 2011)
- 52.225-13 RESTRICTIONS ON CERTAIN FOREIGN PURCHASES (JUNE 2008)
- 52.225-14 INCONSISTENCY BETWEEN ENGLISH VERSION AND TRANSLATION OF CONTRACT (FEB 2000)
- 52.227-3 PATENT INDEMNITIES (APR 1984)
- 52.228-3 WORKERS' COMPENSATION INSURANCE (Defense Base Act) (JUL 2014)
- 52.228-5 INSURANCE - WORK ON A GOVERNMENT INSTALLATION (JAN 1997)
- 52.228-11 PLEDGES OF ASSETS (JAN 2012)
- 52.228-13 ALTERNATIVE PAYMENT PROTECTION (JUL 2000)

- (a) The Contractor shall submit one of the following payment protections: bond, irrevocable letter of credit, or bank letter guarantee
- (b) The amount of the payment protection shall be 50 percent of the contract price.
- (c) The submission of the payment protection is required within 10 days of contract award.
- (d) The payment protection shall provide protection for the full contract performance period plus a one-year period.
- (e) Except for escrow agreements and payment bonds, which provide their own protection procedures, the Contracting Officer is authorized to access funds under the payment protection when it has been alleged in writing by a supplier of labor or material that a nonpayment has occurred, and to withhold such funds pending resolution by administrative or judicial proceedings or mutual agreement of the parties.
- (f) When a tripartite escrow agreement is used, the Contractor shall utilize only suppliers of labor and material that signed the escrow agreement.

(End of clause)

- 52.229-6 TAXES - FOREIGN FIXED-PRICE CONTRACTS (FEB 2013)
- 52.232-5 PAYMENTS UNDER FIXED-PRICE CONSTRUCTION CONTRACTS (SEP 2002)
- 52.232-8 DISCOUNTS FOR PROMPT PAYMENT (FEB 2002)
- 52.232-11 EXTRAS (APR 1984)
- 52.232-17 INTEREST (OCT 2010)
- 52.232-18 AVAILABILITY OF FUNDS (APR 1984)
- 52.232-24 PROHIBITION OF ASSIGNMENT OF CLAIMS (JAN 1986)
- 52.232-27 PROMPT PAYMENT FOR CONSTRUCTION CONTRACTS (JUL 2013)
- 52.232-32 PERFORMANCE-BASED PAYMENTS (APR 2012)
- 52.232-33 PAYMENT BY ELECTRONIC FUNDS TRANSFER—SYSTEM FOR AWARD MANAGEMENT (OCT 2018)
- 52.233-1 DISPUTES (JUL 2002) *Alternate I (DEC 1991)*
- 52.233-3 PROTEST AFTER AWARD (AUG 1996)
- 52.236-2 DIFFERING SITE CONDITIONS (APR 1984)
- 52.236-3 SITE INVESTIGATION AND CONDITIONS AFFECTING THE WORK (APR 1984)
- 52.236-5 MATERIAL AND WORKMANSHIP (APR 1984)
- 52.236-6 SUPERINTENDENCE BY THE CONTRACTOR (APR 1984)
- 52.236-7 PERMITS AND RESPONSIBILITIES (NOV 1991)
- 52.236-8 OTHER CONTRACTS (APR 1984)
- 52.236-9 PROTECTION OF EXISTING VEGETATION, STRUCTURES, EQUIPMENT, UTILITIES, AND IMPROVEMENTS (APR 1984)
- 52.236-10 OPERATIONS AND STORAGE AREAS (APR 1984)

- 52.236-11 USE AND POSSESSION PRIOR TO COMPLETION (APR 1984)
- 52.236-12 CLEANING UP (APR 1984)
- 52.236-13 ACCIDENT PREVENTION (NOV 1991)
- 52.236-14 AVAILABILITY AND USE OF UTILITY SERVICES (APR 1984)
- 52.236-15 SCHEDULES FOR CONSTRUCTION CONTRACTS (APR 1984)
- 52.236-21 SPECIFICATIONS AND DRAWINGS FOR CONSTRUCTION (FEB 1997)
- 52.236-26 PRECONSTRUCTION CONFERENCE (FEB 1995)
- 52.242-14 SUSPENSION OF WORK (APR 1984)
- 52.243-4 CHANGES (JUNE 2007) *Alternate II*
- 52.243-5 CHANGES AND CHANGED CONDITIONS (APR 1984)
- 52.244-6 SUBCONTRACTOR AND COMMERCIAL ITEMS (OCT 2020)
- 52.245-1 GOVERNMENT PROPERTY (APR 2012)
- 52.245-9 USE & CHARGES (APR 2012)
- 52.246-12 INSPECTION OF CONSTRUCTION (AUG 1996)
- 52.246-21 WARRANTY OF CONSTRUCTION (MAR 1994)
- 52.246-26 REPORTING NONFORMING ITEMS (DEC 2019)
- 52.249-2 TERMINATION FOR CONVENIENCE OF THE GOVERNMENT (FIXED-PRICE) (APR 2012) *Alternate I (SEP 1996)*
- 52.249-10 DEFAULT (FIXED-PRICE CONSTRUCTION) (APR 1984)

The following Federal Acquisition Regulation (FAR) clause is set forth in full text:

52.204-25 PROHIBITION ON CONTRACTING FOR CERTAIN TELECOMMUNICATIONS AND VIDEO SURVEILLANCE SERVICES OR EQUIPMENT (AUG 2020)

(a) *Definitions.* As used in this clause—

Covered foreign country means The People's Republic of China.

Covered telecommunications equipment or services means—

(1) Telecommunications equipment produced by Huawei Technologies Company or ZTE Corporation (or any subsidiary or affiliate of such entities);

(2) For the purpose of public safety, security of Government facilities, physical security surveillance of critical infrastructure, and other national security purposes, video surveillance and telecommunications equipment produced by Hytera Communications Corporation, Hangzhou Hikvision Digital Technology Company, or Dahua Technology Company (or any subsidiary or affiliate of such entities);

(3) Telecommunications or video surveillance services provided by such entities or using such equipment; or

(4) Telecommunications or video surveillance equipment or services produced or provided by an entity that the Secretary of Defense, in consultation with the Director of National Intelligence or the Director of the Federal Bureau of Investigation, reasonably believes to be an entity owned or controlled by, or otherwise connected to, the government of a covered foreign country.

Critical technology means—

(1) Defense articles or defense services included on the United States Munitions List set forth in the International Traffic in Arms Regulations under subchapter M of chapter I of title 22, Code of Federal Regulations;

(2) Items included on the Commerce Control List set forth in Supplement No. 1 to part 774 of the Export Administration Regulations under subchapter C of chapter VII of title 15, Code of Federal Regulations, and controlled-

(i) Pursuant to multilateral regimes, including for reasons relating to national security, chemical and biological weapons proliferation, nuclear nonproliferation, or missile technology; or

(ii) For reasons relating to regional stability or surreptitious listening;

(3) Specially designed and prepared nuclear equipment, parts and components, materials, software, and technology covered by part 810 of title 10, Code of Federal Regulations (relating to assistance to foreign atomic energy activities);

(4) Nuclear facilities, equipment, and material covered by part 110 of title 10, Code of Federal Regulations (relating to export and import of nuclear equipment and material);

(5) Select agents and toxins covered by part 331 of title 7, Code of Federal Regulations, part 121 of title 9 of such Code, or part 73 of title 42 of such Code; or

(6) Emerging and foundational technologies controlled pursuant to section 1758 of the Export Control Reform Act of 2018 (50 U.S.C. 4817).

Substantial or essential component means any component necessary for the proper function or performance of a piece of equipment, system, or service.

(b) *Prohibition.* Section 889(a)(1)(A) of the John S. McCain National Defense Authorization Act for Fiscal Year 2019 (Pub. L. 115-232) prohibits the head of an executive agency on or after August 13, 2019, from procuring or obtaining, or extending or renewing a contract to procure or obtain, any equipment, system, or service that uses covered telecommunications equipment or services as a substantial or essential component of any system, or as critical technology as part of any system. The Contractor is prohibited from providing to the Government any equipment, system, or service that uses covered telecommunications equipment or services as a substantial or essential component of any system, or as critical technology as part of any system, unless an exception at paragraph (c) of this clause applies or the covered telecommunication equipment or services are covered by a waiver described in Federal Acquisition Regulation [4.2104](#).

(c) *Exceptions.* This clause does not prohibit contractors from providing—

(1) A service that connects to the facilities of a third-party, such as backhaul, roaming, or interconnection arrangements; or

(2) Telecommunications equipment that cannot route or redirect user data traffic or permit visibility into any user data or packets that such equipment transmits or otherwise handles.

(d) Reporting requirement.

(1) In the event the Contractor identifies covered telecommunications equipment or services used as a substantial or essential component of any system, or as critical technology as part of any system, during contract performance, or the Contractor is notified of such by a subcontractor at any tier or by any other source, the Contractor shall report the information in paragraph (d)(2) of this clause to the Contracting Officer, unless elsewhere in this contract are established procedures for reporting the information; in the case of the Department of Defense, the Contractor shall report to the website at <https://dibnet.dod.mil>. For indefinite delivery contracts, the Contractor shall report to the Contracting Officer for the indefinite delivery contract and the Contracting Officer(s) for any affected order or, in the case of the Department of Defense, identify both the indefinite delivery contract and any affected orders in the report provided at <https://dibnet.dod.mil>.

(2) The Contractor shall report the following information pursuant to paragraph (d)(1) of this clause

(i) Within one business day from the date of such identification or notification: the contract number; the order number(s), if applicable; supplier name; supplier unique entity identifier (if known); supplier Commercial and Government Entity (CAGE) code (if known); brand; model number (original equipment manufacturer number, manufacturer part number, or

wholesaler number); item description; and any readily available information about mitigation actions undertaken or recommended.

(ii) Within 10 business days of submitting the information in paragraph (d)(2)(i) of this clause: any further available information about mitigation actions undertaken or recommended. In addition, the Contractor shall describe the efforts it undertook to prevent use or submission of covered telecommunications equipment or services, and any additional efforts that will be incorporated to prevent future use or submission of covered telecommunications equipment or services.

(e) *Subcontracts*. The Contractor shall insert the substance of this clause, including this paragraph (e), in all subcontracts and other contractual instruments, including subcontracts for the acquisition of commercial items.

(End of clause)

The following Department of State Acquisition Regulation (DOSAR) clauses are set forth in full text:

652.204-70 DEPARTMENT OF STATE PERSONAL IDENTIFICATION CARD
ISSUANCE PROCEDURES (MAY 2011)

(a) The Contractor shall comply with the Department of State (DOS) Personal Identification Card Issuance Procedures for all employees performing under this contract who require frequent and continuing access to DOS facilities, or information systems. The Contractor shall insert this clause in all subcontracts when the subcontractor's employees will require frequent and continuing access to DOS facilities, or information systems.

(b) The DOS Personal Identification Card Issuance Procedures may be accessed at <http://www.state.gov/m/ds/rls/rpt/c21664.htm>.

(End of clause)

CONTRACTOR IDENTIFICATION (JULY 2008)

Contract performance may require contractor personnel to attend meetings with government personnel and the public, work within government offices, and/or utilize government email.

Contractor personnel must take the following actions to identify themselves as non-federal employees:

- 1) Use an email signature block that shows name, the office being supported and company affiliation (e.g. “John Smith, Office of Human Resources, ACME Corporation Support Contractor”);
- 2) Clearly identify themselves and their contractor affiliation in meetings;
- 3) Identify their contractor affiliation in Departmental e-mail and phone listings whenever contractor personnel are included in those listings; and
- 4) Contractor personnel may not utilize Department of State logos or indicia on business cards.

(End of clause)

652.229-71 PERSONAL PROPERTY DISPOSITION AT POSTS ABROAD (AUG 1999)

Regulations at 22 CFR Part 136 require that U.S. Government employees and their families do not profit personally from sales or other transactions with persons who are not themselves entitled to exemption from import restrictions, duties, or taxes. Should the Contractor experience importation or tax privileges in a foreign country because of its contractual relationship to the United States Government, the Contractor shall observe the requirements of 22 CFR Part 136 and all policies, rules, and procedures issued by the chief of mission in that foreign country.

652.236-70 ADDITIONAL SAFETY MEASURES (OCT 2017)

In addition to the safety/accident prevention requirements of FAR 52.236-13, Accident Prevention Alternate I, the contractor shall comply with the following additional safety measures.

(a) *High Risk Activities.* If the project contains any of the following high risk activities, the contractor shall follow the section in the latest edition, as of the date of the solicitation, of the U.S. Army Corps of Engineers Safety and Health manual, EM 385-1-1, that corresponds to the high risk activity. Before work may proceed, the contractor must obtain approval from the COR of the written safety plan required by FAR 52.236-13, Accident Prevention Alternate I (see paragraph (f) below), containing specific hazard mitigation and control techniques.

- (1) Scaffolding;
- (2) Work at heights above 1.8 meters;
- (3) Trenching or other excavation greater than one (1) meter in depth;
- (4) Earth-moving equipment and other large vehicles;

(5) Cranes and rigging;

(6) Welding or cutting and other hot work;

(7) Partial or total demolition of a structure;

(8) Temporary wiring, use of portable electric tools, or other recognized electrical hazards. Temporary wiring and portable electric tools require the use of a ground fault circuit interrupter (GFCI) in the affected circuits; other electrical hazards may also require the use of a GFCI;

(9) Work in confined spaces (limited exits, potential for oxygen less than 19.5 percent or combustible atmosphere, potential for solid or liquid engulfment, or other hazards considered to be immediately dangerous to life or health such as water tanks, transformer vaults, sewers, cisterns, etc.);

(10) Hazardous materials - a material with a physical or health hazard including but not limited to, flammable, explosive, corrosive, toxic, reactive or unstable, or any operations, which creates any kind of contamination inside an occupied building such as dust from demolition activities, paints, solvents, etc.; or

(11) Hazardous noise levels as required in EM 385-1 Section 5B or local standards if more restrictive.

(b) *Safety and Health Requirements.* The contractor and all subcontractors shall comply with the latest edition of the U.S. Army Corps of Engineers Safety and Health manual EM 385-1-1, or OSHA 29 CFR parts 1910 or 1926 if no EM 385-1-1 requirements are applicable, and the accepted contractor's written safety program.

(c) *Mishap Reporting.* The contractor is required to report **immediately** all mishaps to the COR and the contracting officer. A "mishap" is any event causing injury, disease or illness, death, material loss or property damage, or incident causing environmental contamination. The mishap reporting requirement shall include fires, explosions, hazardous materials contamination, and other similar incidents that may threaten people, property, and equipment.

(d) *Records.* The contractor shall maintain an accurate record on all mishaps incident to work performed under this contract resulting in death, traumatic injury, occupational disease, or damage to or theft of property, materials, supplies, or equipment. The contractor shall report this data in the manner prescribed by the contracting officer.

(e) *Subcontracts.* The contractor shall insert this clause, including this paragraph (e), with appropriate changes in the designation of the parties, in subcontracts.

(f) *Written program.* The plan required by paragraph (f)(1) of the clause entitled "Accident Prevention Alternate I" shall be known as the Site Safety and Health Plan (SSHP) and shall address any activities listed in paragraph (a) of this clause, or as otherwise required by the contracting officer/COR.

(1) The SSHP shall be submitted at least 10 working days prior to commencing any activity at the site.

(2) The plan must address developing activity hazard analyses (AHAs) for specific tasks. The AHAs shall define the activities being performed and identify the work sequences, the specific anticipated hazards, site conditions, equipment, materials, and the control measures to be implemented to eliminate or reduce each hazard to an acceptable level of risk. Work shall not begin until the AHA for the work activity has been accepted by the COR and discussed with all engaged in the activity, including the Contractor, subcontractor(s), and Government on-site representatives.

(3) The names of the Competent/Qualified Person(s) required for a particular activity (for example, excavations, scaffolding, fall protection, other activities as specified by EM 385-1-1) shall be identified and included in the AHA. Proof of their competency/qualification shall be submitted to the contracting officer or COR for acceptance prior to the start of that work activity. The AHA shall be reviewed and modified as necessary to address changing site conditions, operations, or change of competent/qualified person(s).

(End of clause)

652.242-73 AUTHORIZATION AND PERFORMANCE (AUG 1999)

(a) The contractor warrants the following:

- (1) That it has obtained authorization to operate and do business in the country or countries in which this contract will be performed;
- (2) That it has obtained all necessary licenses and permits required to perform this contract; and,
- (3) That it shall comply fully with all laws, decrees, labor standards, and regulations of said country or countries during the performance of this contract.

(b) If the party actually performing the work will be a subcontractor or joint venture partner, then such subcontractor or joint venture partner agrees to the requirements of paragraph (a) of this clause.

652.243-70 NOTICES (AUG 1999)

Any notice or request relating to this contract given by either party to the other shall be in writing. Said notice or request shall be mailed or delivered by hand to the other party at the address provided in the schedule of the contract. All modifications to the contract must be made in writing by the Contracting Officer.

I. SECTION I- INSTRUCTION ON HOW TO SUBMIT A QUOTATION

The Offeror shall include Defense Base Act (DBA) insurance premium costs covering employees. The offeror may obtain DBA insurance directly from any Department of Labor approved providers at the DOL website at <http://www.dol.gov/owcp/dlhwc/lscarrier.htm>

I.1 SUBMISSION OF QUOTATIONS

This solicitation is for the performance of the services described in Section B.

Summary of Instructions

Each quotation must consist of the following physically separate volumes:

Volume	Title	Number of Copies
1	Executed Standard Form 18 (SF-18)	1
2	Management Information	2

Submit the complete quotation to the address on the SF-18.

The quoter shall state any deviations, exceptions, or conditional assumptions taken regarding this solicitation and explain/justify them in the appropriate volume of the offer.

1. Volume 1 shall contain complete pricing schedules.
2. Volume 2 shall include information demonstrating the quoter's ability to perform including:
 - (A) Evidence that the quoter operates an established business with a permanent address and telephone listing;
 - (B) Evidence that the quoter is in the information technology solution business for no less than five (5) years.
 - (C) Evidence that the quoter has worked in installing networking cable project before and the value of that project must not be less than \$100,000;
 - (D) List of references of previous clients and projects, including contact information and detailed project information (description, price, duration, etc)
 - (E) Other requirements outline in Section J

I.2 Submit the complete quotation to the address indicated on the solicitation cover page, if mailed, or the address set forth below, if hand delivered.

Scott M. Krushinski, Contracting Officer
GSO/Procurement Unit
U.S. Embassy Bangkok
5th floor, Tower A
GPF Building, 93/1 Wireless Rd.
Lumpini, Pathumwan,
Bangkok, Thailand 10330

Quotations submitted after the due date and time indicated on the SF-18 cover sheet may not be considered.

I.3 52.252-1 SOLICITATION PROVISIONS INCORPORATED BY REFERENCE (FEB 1998)

This solicitation incorporates one or more solicitation provisions by reference, with the same force and effect as if they were given in full text. Upon request, the Contracting Officer will make their full text available. In addition, the full text of a clause may be accessed electronically at Acquisition.gov this address is subject to change.

If the Federal Acquisition Regulation (FAR) is not available at the location indicated above, use the Department of State Acquisition website at e-CFR to see the links to the FAR. You may also use an Internet “search engine” (for example, Google, Yahoo or Excite) to obtain the latest location of the most current FAR.

<u>PROVISION</u>	<u>TITLE AND DATE</u>
52.204-7	SYSTEM FOR AWARD MANAGEMENT (OCT 2016)
52.204-16	COMMERCIAL AND GOVERNMENT ENTITY CODE REPORTING (JUL 2016)
52.214-34	SUBMISSION OF OFFERS IN THE ENGLISH LANGUAGE (APR 1991)
52.215-1	INSTRUCTIONS TO OFFERORS—COMPETITIVE ACQUISITION (JAN 2004)

I-3 SOLICITATION PROVISIONS INCORPORATED BY FULL TEXT

52.216-1 TYPE OF CONTRACT (APR 1984)

The Government contemplates award of a Labor-Hour purchase order resulting from this solicitation.

52.233-2 SERVICE OF PROTEST (SEPT 2006)

(a) Protests, as defined in section 33.101 of the Federal Acquisition Regulation, that are filed directly with an agency, and copies of any protests that are filed with the General Accounting Office (GAO), shall be served on the Contracting Officer (addressed as follows) by obtaining written and dated acknowledgment of receipt from ***GSO/Procurement Unit, U.S. Embassy Bangkok, 120-122, Wireless Rd., Lumpini, Pathumwan, Bangkok, Thailand, 10330.***

(b) The copy of any protest shall be received in the office designated above within one day of filing a protest with the GAO.

(End of provision)

J. QUOTATION INFORMATION

J.1 QUALIFICATIONS OF OFFERORS

Offerors must be technically qualified and financially responsible to perform the work described in this solicitation. At a minimum, each Offeror must meet the following requirements:

- (1) Be able to understand written and spoken English;
- (2) Have an established business with a permanent address and telephone listing;
- (3) Be able to demonstrate prior IT communications cable design and installation experience with suitable references;
- (4) Have the necessary personnel, equipment and financial resources available to perform the work;
- (5) Have all licenses and permits required by local law;
- (6) Meet all local insurance requirements;
- (7) Have the ability to obtain or to post adequate performance security, such as bonds, irrevocable letters of credit or guarantees issued by a reputable financial institution;
- (8) Have no adverse criminal record; and
- (9) Have no political or business affiliation which could be considered contrary to the interests of the United States.

J.2 SUBMISSION OF QUOTATIONS

This solicitation is for the performance of the construction services described in SCOPE OF WORK, and the Attachments which are a part of this request for quotation.

Each quotation must consist of the following:

<u>Volume No.</u>	<u>Title</u>	<u>No. of Copies*</u>
1	Standard Form 18	1
2	Performance schedule in the form of a "bar chart" and Business Management/Technical Proposal	2

The complete quotation shall be submitted at the address indicated on Standard Form 18, if mailed, or the address set forth below, if hand delivered.

Scott M. Krushinski, Contracting Officer
GSO/Procurement Unit
5th floor, Tower A, GPF Building, 93/1 Wireless Rd.
Lumpini, Pathumwan, Bangkok, Thailand 10330

Any deviations, exceptions, or conditional assumptions taken with respect to any of the instructions or requirements of this request for quotation shall be identified and explained/justified in the appropriate volume of the offer.

Volume II: Performance schedule and Business Management/Technical Proposal.

(a) The performance schedule shall be presented in the form of a "bar chart" indicating when the various portions of the work will be commenced and completed within the required contract completion schedule. This bar chart shall be in sufficient detail to clearly show each segregable portion of work and its planned commencement and completion date.

(b) The Business Management/Technical Proposal shall be in two parts, including the following information:

Proposed Work Information - provide the following:

- (1) A list of the names, addresses and telephone numbers of the owners, partners, and principal officers of the Offeror;
- (2) The name and address of the Offeror's field superintendent for this project; and
- (3) A list of the names, addresses, and telephone numbers of subcontractors and principal materials suppliers to be used on the project, indicating what portions of the work will be performed by them. Along with the list of suppliers provide the product data sheets for cabling to be used for this project.
- (4) Bar chart indicating various portions of the work; when work will commence and be completed in each section

Experience and Past Performance - List all contracts and subcontracts your company has held over the past three years for the same or similar work. Provide the following information for each contract and subcontract:

- (1) Customer's name, address, and telephone numbers of customer's lead contract and technical personnel;
- (2) Contract number and type;
- (3) Date of the contract award place(s) of performance, and completion dates; Contract dollar value;
- (4) Brief description of the work, including responsibilities;
- (5) Any litigation currently in process or occurring within last 5 years
- (6) A list of projects using ANSI/TIA/EIA standards.

(a) The clauses at 52.236-2, Differing Site Conditions, and 52.236-3, Site Investigations and Conditions Affecting the Work, will be included in any contract awarded as a result of this solicitation. Accordingly, offerors or quoters are urged and expected to inspect the site where the work will be performed.

(b) An organized site visit has been schedule for **February 4, 2021 at 10.00 hrs.**

(c) Participants will meet at ILEA Bangkok, 88/8 Moo 3, Vibhavadi-Rangsit Road, Talad Bangkhen, Laksi, Bangkok, Thailand, 10210

J.4 MAGNITUDE OF CONSTRUCTION PROJECT

It is anticipated that the range in price of this contract will be between \$25,000 and \$100,000.

J.5. LATE QUOTATIONS.

Late quotations shall be handled in accordance with FAR 52.215-1 Instructions to Offerors – Competitive Acquisition (JAN 2004), which is incorporated by reference into this solicitation.

K. EVALUATION CRITERIA

Award will be made to the lowest priced, acceptable, responsible quoter. The Government reserves the right to reject quotations that are unreasonably low or high in price.

The Offeror shall include Defense Base Act (DBA) insurance premium costs covering employees. The offeror may obtain DBA insurance directly from any Department of Labor approved providers at the DOL website at <http://www.dol.gov/owcp/dlhwc/lscarrier.htm>

Acceptability will be determined by assessing the offeror's compliance with the terms of the RFQ. Responsibility will be determined by analyzing whether the apparent successful quoter complies with the requirements of FAR 9.1, including:

- ability to comply with the required performance period, taking into consideration all existing commercial and governmental business commitments;
- satisfactory record of integrity and business ethics;
- necessary organization, experience, and skills or the ability to obtain them;
- necessary equipment and facilities or the ability to obtain them; and
- otherwise qualified and eligible to receive an award under applicable laws and regulations.

SECTION L - REPRESENTATIONS, CERTIFICATIONS AND OTHER
STATEMENTS OF OFFERORS OR QUOTERS

L.1 52.204-3 TAXPAYER IDENTIFICATION (OCT 1998)

(a) Definitions

"Common parent", as used in this provision, means that corporate entity that owns or controls an affiliated group of corporations that files its Federal income tax returns on a consolidated basis, and of which the offeror is a member.

"Taxpayer Identification Number (TIN)", as used in this provision, means the number required by the IRS to be used by the offeror in reporting income tax and other returns. The TIN may be either a Social Security Number or an Employer Identification Number.

(b) All offerors must submit the information required in paragraphs (d)through (f) of this provision in order to comply with debt collection requirements of 31 U.S.C. 7701(c) and 3325 (d), reporting requirements of 26 USC 6041, 6041A, and 6050M and implementing regulations issued by the Internal Revenue Service (IRS). If the resulting contract is subject to the reporting requirements described in FAR 4.904, the failure or refusal by the offeror to furnish the information may result in a 31 percent reduction of payments otherwise due under the contract.

(c) The TIN may be used by the Government to collect and report on any delinquent amounts arising out of the offeror's relationship with the Government (31 USC 7701(c)(3)). If the resulting contract is subject to the payment reporting requirements described in FAR 4.904, the TIN provided hereunder may be matched with IRS records to verify the accuracy of the offeror's TIN.

(d) Taxpayer Identification Number (TIN)

TIN:	
<input type="checkbox"/>	TIN has been applied for
<input type="checkbox"/>	TIN is not required because:
<input type="checkbox"/>	Offeror is a nonresident alien, foreign corporation, or foreign partnership that does not have income effectively connected with the conduct of a trade or business in the U.S. and does not have an office or place of business or a fiscal paying agent in the U.S.
<input type="checkbox"/>	Offeror is an agency or instrumentality of a foreign government
<input type="checkbox"/>	Offeror is an agency or instrumentality of the Federal Government

(e) Type of Organization

<input type="checkbox"/>	Sole Proprietorship
<input type="checkbox"/>	Partnership
<input type="checkbox"/>	Corporate Entity (not tax exempt)
<input type="checkbox"/>	Corporate Entity (tax exempt)
<input type="checkbox"/>	Government entity (Federal, State or local)

	Foreign Government
	International organization per 26 CFR 1.6049-4
	Other:

(f) Common Parent

	Offeror is not owned or controlled by a common parent as defined in paragraph (a) of this clause.
	Name and TIN of common parent
Name	
TIN	

(End of provision)

L.2 FAR 52.204-8 ANNUAL REPRESENTATIONS AND CERTIFICATIONS (MAR 2020)

(a) (1) The North American Industry Classification System (NAICS) code for this acquisition is _____ *[insert NAICS code]*.

(2) The small business size standard is _____ *[insert size standard]*.

(3) The small business size standard for a concern which submits an offer in its own name, other than on a construction or service contract, but which proposes to furnish a product which it did not itself manufacture, is 500 employees.

(b) (1) If the provision at [52.204-7](#), System for Award Management, is included in this solicitation, paragraph (d) of this provision applies.

(2) If the provision at [52.204-7](#), System for Award Management, is not included in this solicitation, and the Offeror has an active registration in the System for Award Management (SAM), the Offeror may choose to use paragraph (d) of this provision instead of completing the corresponding individual representations and certifications in the solicitation. The Offeror shall indicate which option applies by checking one of the following boxes:

(i) Paragraph (d) applies.

(ii) Paragraph (d) does not apply and the offeror has completed the individual representations and certifications in the solicitation.

(c) (1) The following representations or certifications in SAM are applicable to this solicitation as indicated:

(i) [52.203-2](#), Certificate of Independent Price Determination. This provision applies to solicitations when a firm-fixed-price contract or fixed-price contract with economic price adjustment is contemplated, unless—

(A) The acquisition is to be made under the simplified acquisition procedures in [part 13](#);

(B) The solicitation is a request for technical proposals under two-step sealed bidding procedures; or

(C) The solicitation is for utility services for which rates are set by law or regulation.

(ii) [52.203-11](#), Certification and Disclosure Regarding Payments to Influence Certain Federal Transactions. This provision applies to solicitations expected to exceed \$150,000.

(iii) [52.203-18](#), Prohibition on Contracting with Entities that Require Certain Internal Confidentiality Agreements or Statements-Representation. This provision applies to all solicitations.

(iv) [52.204-3](#), Taxpayer Identification. This provision applies to solicitations that do not include the provision at [52.204-7](#), System for Award Management.

(v) [52.204-5](#), Women-Owned Business (Other Than Small Business). This provision applies to solicitations that-

(A) Are not set aside for small business concerns;

(B) Exceed the simplified acquisition threshold; and

(C) Are for contracts that will be performed in the United States or its outlying areas.

(vi) [52.204-26](#), Covered Telecommunications Equipment or Services-Representation. This provision applies to all solicitations.

(vii) [52.209-2](#), Prohibition on Contracting with Inverted Domestic Corporations-Representation.

(viii) [52.209-5](#), Certification Regarding Responsibility Matters. This provision applies to solicitations where the contract value is expected to exceed the simplified acquisition threshold.

(ix) [52.209-11](#), Representation by Corporations Regarding Delinquent Tax Liability or a Felony Conviction under any Federal Law. This provision applies to all solicitations.

(x) [52.214-14](#), Place of Performance-Sealed Bidding. This provision applies to invitations for bids except those in which the place of performance is specified by the Government.

(xi) [52.215-6](#), Place of Performance. This provision applies to solicitations unless the place of performance is specified by the Government.

(xii) [52.219-1](#), Small Business Program Representations (Basic, Alternates I, and II). This provision applies to solicitations when the contract will be performed in the United States or its outlying areas.

(A) The basic provision applies when the solicitations are issued by other than DoD, NASA, and the Coast Guard.

(B) The provision with its Alternate I applies to solicitations issued by DoD, NASA, or the Coast Guard.

(C) The provision with its Alternate II applies to solicitations that will result in a multiple-award contract with more than one NAICS code assigned.

(xiii) [52.219-2](#), Equal Low Bids. This provision applies to solicitations when contracting by sealed bidding and the contract will be performed in the United States or its outlying areas.

(xiv) [52.222-22](#), Previous Contracts and Compliance Reports. This provision applies to solicitations that include the clause at [52.222-26](#), Equal Opportunity.

(xv) [52.222-25](#), Affirmative Action Compliance. This provision applies to solicitations, other than those for construction, when the solicitation includes the clause at [52.222-26](#), Equal Opportunity.

(xvi) [52.222-38](#), Compliance with Veterans' Employment Reporting Requirements. This provision applies to solicitations when it is anticipated the contract award will exceed the simplified acquisition threshold and the contract is not for acquisition of commercial items.

(xvii) [52.223-1](#), Biobased Product Certification. This provision applies to solicitations that require the delivery or specify the use of USDA–designated items; or include the clause at [52.223-2](#), Affirmative Procurement of Biobased Products Under Service and Construction Contracts.

(xviii) [52.223-4](#), Recovered Material Certification. This provision applies to solicitations that are for, or specify the use of, EPA–designated items.

(xix) [52.223-22](#), Public Disclosure of Greenhouse Gas Emissions and Reduction Goals-Representation. This provision applies to solicitations that include the clause at [52.204-7](#).)

(xx) [52.225-2](#), Buy American Certificate. This provision applies to solicitations containing the clause at [52.225-1](#).

(xxi) [52.225-4](#), Buy American-Free Trade Agreements-Israeli Trade Act Certificate. (Basic, Alternates I, II, and III.) This provision applies to solicitations containing the clause at [52.225-3](#).

(A) If the acquisition value is less than \$25,000, the basic provision applies.

(B) If the acquisition value is \$25,000 or more but is less than \$50,000, the provision with its Alternate I applies.

(C) If the acquisition value is \$50,000 or more but is less than \$83,099, the provision with its Alternate II applies.

(D) If the acquisition value is \$83,099 or more but is less than \$100,000, the provision with its Alternate III applies.

(xxii) [52.225-6](#), Trade Agreements Certificate. This provision applies to solicitations containing the clause at [52.225-5](#).

(xxiii) [52.225-20](#), Prohibition on Conducting Restricted Business Operations in Sudan-Certification. This provision applies to all solicitations.

(xxiv) [52.225-25](#), Prohibition on Contracting with Entities Engaging in Certain Activities or Transactions Relating to Iran-Representation and Certifications. This provision applies to all solicitations.

(xxv) [52.226-2](#), Historically Black College or University and Minority Institution Representation. This provision applies to solicitations for research, studies, supplies, or services of the type normally acquired from higher educational institutions.

(2) The following representations or certifications are applicable as indicated by the Contracting Officer:

[Contracting Officer check as appropriate.]

___ (i) [52.204-17](#), Ownership or Control of Offeror.

___ (ii) [52.204-20](#), Predecessor of Offeror.

___ (iii) [52.222-18](#), Certification Regarding Knowledge of Child Labor for Listed End Products.

___ (iv) [52.222-48](#), Exemption from Application of the Service Contract Labor Standards to Contracts for Maintenance, Calibration, or Repair of Certain Equipment-Certification.

___ (v) [52.222-52](#), Exemption from Application of the Service Contract Labor Standards to Contracts for Certain Services-Certification.

___ (vi) [52.223-9](#), with its Alternate I, Estimate of Percentage of Recovered Material Content for EPA-Designated Products (Alternate I only).

___ (vii) [52.227-6](#), Royalty Information.

___ (A) Basic.

___ (B) Alternate I.

___ (viii) [52.227-15](#), Representation of Limited Rights Data and Restricted Computer Software.

(d) The offeror has completed the annual representations and certifications electronically in SAM website accessed through <https://www.sam.gov>. After reviewing the SAM information, the offeror verifies by submission of the offer that the representations and certifications currently posted electronically that apply to this solicitation as indicated in paragraph (c) of this provision have been entered or updated within the last 12 months, are current, accurate, complete, and applicable to this solicitation (including the business size standard applicable to the NAICS code referenced for this solicitation), as of the date of this offer and are incorporated in this offer by reference (see FAR [4.1201](#)); except for the changes identified below [*offeror to insert changes, identifying change by clause number, title, date*]. These amended representation(s) and/or certification(s) are also incorporated in this offer and are current, accurate, and complete as of the date of this offer.

FAR Clause #	Title	Date	Change

Any changes provided by the offeror are applicable to this solicitation only, and do not result in an update to the representations and certifications posted on SAM

(End of provision)

L.2 52.204-24 Representation Regarding Certain Telecommunications and Video Surveillance Services or Equipment (OCT 2020).

The Offeror shall not complete the representation at paragraph (d)(1) of this provision if the offeror has represented that it “does not provide covered telecommunications equipment or services as a part of its offered products or services to the Government in the performance of any contract, subcontract, or other contractual instrument” in paragraph (c)(1) in the provision at 52.204-26, Covered Telecommunications Equipment or Services—Representation, or in paragraph (v)(2)(i) of the provision at 52.212-3,

Offeror Representations and Certifications—Commercial Items. The Offeror shall not complete the representation in paragraph (d)(2) of this provision if the Offeror has represented that it “does not use covered telecommunications equipment or services, or any equipment, system, or service that uses covered telecommunications equipment or services” in paragraph (c)(2) of the provision at 52.204–26, or in paragraph (v)(2)(ii) of the provision at 52.212–3.

(a) *Definitions.* As used in this provision—

Backhaul, covered telecommunications equipment or services, critical technology, interconnection arrangements, reasonable inquiry, roaming, and substantial or essential component have the meanings provided in the clause [52.204-25](#), Prohibition on Contracting for Certain Telecommunications and Video Surveillance Services or Equipment.

(b) *Prohibition.*

(1) Section 889(a)(1)(A) of the John S. McCain National Defense Authorization Act for Fiscal Year 2019 (Pub. L. 115-232) prohibits the head of an executive agency on or after August 13, 2019, from procuring or obtaining, or extending or renewing a contract to procure or obtain, any equipment, system, or service that uses covered telecommunications equipment or services as a substantial or essential component of any system, or as critical technology as part of any system. Nothing in the prohibition shall be construed to—

(i) Prohibit the head of an executive agency from procuring with an entity to provide a service that connects to the facilities of a third-party, such as backhaul, roaming, or interconnection arrangements; or

(ii) Cover telecommunications equipment that cannot route or redirect user data traffic or cannot permit visibility into any user data or packets that such equipment transmits or otherwise handles.

(2) Section 889(a)(1)(B) of the John S. McCain National Defense Authorization Act for Fiscal Year 2019 (Pub. L. 115-232) prohibits the head of an executive agency on or after August 13, 2020, from entering into a contract or extending or renewing a contract with an entity that uses any equipment, system, or service that uses covered telecommunications equipment or services as a substantial or essential component of any system, or as critical technology as part of any system. This prohibition applies to the use of covered telecommunications equipment or services, regardless of whether that use is in performance of work under a Federal contract. Nothing in the prohibition shall be construed to—

(i) Prohibit the head of an executive agency from procuring with an entity to provide a service that connects to the facilities of a third-party, such as backhaul, roaming, or interconnection arrangements; or

(ii) Cover telecommunications equipment that cannot route or redirect user data traffic or cannot permit visibility into any user data or packets that such equipment transmits or otherwise handles.

(c) *Procedures.* The Offeror shall review the list of excluded parties in the System for Award Management (SAM) (<https://www.sam.gov>) for entities excluded from receiving federal awards for “covered telecommunications equipment or services”.

(d) *Representation.* The Offeror represents that—

(1) It will, will not provide covered telecommunications equipment or services to the Government in the performance of any contract, subcontract or other contractual instrument resulting from this solicitation. The Offeror shall provide the additional disclosure information required at paragraph (e)(1) of this section if the Offeror responds “will” in paragraph (d)(1) of this section; and

(2)After conducting a reasonable inquiry, for purposes of this representation, the Offeror represents that—

It does, does not use covered telecommunications equipment or services, or use any equipment, system, or service that uses covered telecommunications equipment or services. The Offeror shall provide the additional disclosure information required at paragraph (e)(2) of this section if the Offeror responds “does” in paragraph (d)(2) of this section.

(e) *Disclosures.*

(1) Disclosure for the representation in paragraph (d)(1) of this provision. If the Offeror has responded “will” in the representation in paragraph (d)(1) of this provision, the Offeror shall provide the following information as part of the offer:

(i)For covered equipment—

(A)The entity that produced the covered telecommunications equipment (include entity name, unique entity identifier, CAGE code, and whether the entity was the original equipment manufacturer (OEM) or a distributor, if known);

(B)A description of all covered telecommunications equipment offered (include brand; model number, such as OEM number, manufacturer part number, or wholesaler number; and item description, as applicable); and

(C)Explanation of the proposed use of covered telecommunications equipment and any factors relevant to determining if such use would be permissible under the prohibition in paragraph (b)(1) of this provision.

(ii)For covered services—

(A)If the service is related to item maintenance: A description of all covered telecommunications services offered (include on the item being maintained: Brand; model number, such as OEM number, manufacturer part number, or wholesaler number; and item description, as applicable); or

(B)If not associated with maintenance, the Product Service Code (PSC) of the service being provided; and explanation of the proposed use of covered telecommunications services and any factors relevant to determining if such use would be permissible under the prohibition in paragraph (b)(1) of this provision.

(2) Disclosure for the representation in paragraph (d)(2) of this provision. If the Offeror has responded “does” in the representation in paragraph (d)(2) of this provision, the Offeror shall provide the following information as part of the offer:

(i)For covered equipment—

(A)The entity that produced the covered telecommunications equipment (include entity name, unique entity identifier, CAGE code, and whether the entity was the OEM or a distributor, if known);

(B)A description of all covered telecommunications equipment offered (include brand; model number, such as OEM number, manufacturer part number, or wholesaler number; and item description, as applicable); and

(C)Explanation of the proposed use of covered telecommunications equipment and any factors relevant to determining if such use would be permissible under the prohibition in paragraph (b)(2) of this provision.

(ii)For covered services—

(A)If the service is related to item maintenance: A description of all covered telecommunications services offered (include on the item being maintained: Brand; model number, such as OEM number, manufacturer part number, or wholesaler number; and item description, as applicable); or

(B)If not associated with maintenance, the PSC of the service being provided; and explanation of the proposed use of covered telecommunications services and any factors relevant to determining if such use would be permissible under the prohibition in paragraph (b)(2) of this provision.

(End of provision)

L.3 52.204-26 Covered Telecommunications Equipment or Services-Representation (OCT 2020)

(a) *Definitions.* As used in this provision, “covered telecommunications equipment or services” and “reasonable inquiry” have the meaning provided in the clause 52.204-25, Prohibition on Contracting for Certain Telecommunications and Video Surveillance Services or Equipment.

(b) *Procedures.* The Offeror shall review the list of excluded parties in the System for Award Management (SAM) (<https://www.sam.gov>) for entities excluded from receiving federal awards for “covered telecommunications equipment or services”.

(c) *Representations.* (1) The Offeror represents that it [] does, [] does not provide covered telecommunications equipment or services as a part of its offered products or services to the Government in the performance of any contract, subcontract, or other contractual instrument.

(2) After conducting a reasonable inquiry for purposes of this representation, the Offeror represents that it [] does, [] does not use covered telecommunications equipment or services, or any equipment, system, or service that uses covered telecommunications equipment or services.

(End of Provision)

L.4. 52.225-18 PLACE OF MANUFACTURE (SEPT 2006)

(a) *Definitions.* As used in this clause—

“Manufactured end product” means any end product in Federal Supply Classes (FSC) 1000-9999, except—

(1) FSC 5510, Lumber and Related Basic Wood Materials;

- (2) Federal Supply Group (FSG) 87, Agricultural Supplies;
- (3) FSG 88, Live Animals;
- (4) FSG 89, Food and Related Consumables;
- (5) FSC 9410, Crude Grades of Plant Materials;
- (6) FSC 9430, Miscellaneous Crude Animal Products, Inedible;
- (7) FSC 9440, Miscellaneous Crude Agricultural and Forestry Products;
- (8) FSC 9610, Ores;
- (9) FSC 9620, Minerals, Natural and Synthetic; and
- (10) FSC 9630, Additive Metal Materials.

“Place of manufacture” means the place where an end product is assembled out of components, or otherwise made or processed from raw materials into the finished product that is to be provided to the Government. If a product is disassembled and reassembled, the place of reassembly is not the place of manufacture.

(b) For statistical purposes only, the offeror shall indicate whether the place of manufacture of the end products it expects to provide in response to this solicitation is predominantly—

- (1) In the United States (Check this box if the total anticipated price of offered end products manufactured in the United States exceeds the total anticipated price of offered end products manufactured outside the United States); or
- (2) Outside the United States.

(End of provision)

L.4. AUTHORIZED CONTRACT ADMINISTRATOR

If the offeror does not fill-in the blanks below, the official who signed the offer will be deemed to be the offeror's representative for Contract Administration, which includes all matters pertaining to payments.

Name:	
Address:	
Telephone Number:	
E-Mail address:	

(End of provision)

L.5 52.225-20 PROHIBITION ON CONDUCTING RESTRICTED BUSINESS OPERATIONS IN SUDAN—CERTIFICATION (AUG 2009)

(a) *Definitions.* As used in this provision—

“Business operations” means engaging in commerce in any form, including by acquiring, developing, maintaining, owning, selling, possessing, leasing, or operating equipment, facilities, personnel, products, services, personal property, real property, or any other apparatus of business or commerce.

“Marginalized populations of Sudan” means—

- (1) Adversely affected groups in regions authorized to receive assistance under section 8(c) of the Darfur Peace and Accountability Act (Pub. L. 109-344) ([50 U.S.C. 1701 note](#)); and
- (2) Marginalized areas in Northern Sudan described in section 4(9) of such Act.

“Restricted business operations” means business operations in Sudan that include power production activities, mineral extraction activities, oil-related activities, or the production of military equipment, as those terms are defined in the Sudan Accountability and Divestment Act of 2007 (Pub. L. 110-174). Restricted business operations do not include business operations that the person conducting the business can demonstrate—

- (1) Are conducted under contract directly and exclusively with the regional government of southern Sudan;
- (2) Are conducted pursuant to specific authorization from the Office of Foreign Assets Control in the Department of the Treasury, or are expressly exempted under Federal law from the requirement to be conducted under such authorization;
- (3) Consist of providing goods or services to marginalized populations of Sudan;
- (4) Consist of providing goods or services to an internationally recognized peacekeeping force or humanitarian organization;
- (5) Consist of providing goods or services that are used only to promote health or education;
- or
- (6) Have been voluntarily suspended.

(b) *Certification.* By submission of its offer, the offeror certifies that it does not conduct any restricted business operations in Sudan.

(End of provision)

L.6. 52.209-2 PROHIBITION ON CONTRACTING WITH INVERTED DOMESTIC CORPORATIONS REPRESENTATION (NOV 2015)

(a) Definitions. “Inverted domestic corporation” and “subsidiary” have the meaning given in the clause of this contract entitled Prohibition on Contracting with Inverted Domestic Corporations ([52.209-10](#)).

(b) Government agencies are not permitted to use appropriated (or otherwise made available) funds for contracts with either an inverted domestic corporation, or a subsidiary of an inverted domestic corporation, unless the exception at [9.108-2\(b\)](#) applies or the requirement is waived in accordance with the procedures at [9.108-4](#).

(c) Representation. The Offeror represents that.

- (1) It is, is not an inverted domestic corporation; and
- (2) It is, is not a subsidiary of an inverted domestic corporation.

(End of provision)

ATTACHMENT #1 - DRAWINGS

